



Chain Saw

Instruction Manual

MODELS : CS-330T

WARNING **DANGER**



The muffler or catalytic muffler and surrounding cover may become extremely hot.

Always keep clear of exhaust and muffler area, otherwise serious personal injury may occur.



WARNING



The engine exhaust from this product contains chemicals known to the State of California to cause cancer, birth defects or other reproductive harm.



WARNING

Users of this equipment risk injury to themselves and others if the unit is used improperly and/or safety precautions are not followed. ECHO provides an operator's manual and a safety manual. Both must be read and understood for proper and safe operation. Failure to do so could result in serious injury.

CONTENTS

PACKING LIST	3
RULES FOR SAFE OPERATION.....	4
SYMBOLS AND SIGNS.....	8
DECALS	9
EMISSION DATA.....	9
NOMENCLATURE OF PARTS	10
PREPARATION FOR USE	11
FUEL AND LUBRICANT.....	13
OPERATION.....	15
CUTTING INSTRUCTIONS.....	18
CHAIN AND GUIDE BAR COMBINATIONS.....	21
MAINTENANCE AND CARE	22
Carburetor Adjustment.....	23
High Altitude Operation.....	23
SHARPENING THE CHAIN	30
TROUBLESHOOTING	31
STORAGE AFTER USE	32
TECHNICAL DATA	33
WARRANTY STATEMENTS	34
SERVICING INFORMATION.....	36

This chain saw is designed for cutting wood or wood products. Do not cut solid metal, sheet metal, plastic or any non-wood materials.

Specifications, descriptions and illustrative material in this literature are as accurate as known at the time of publication, but are subject to change without notice.

Illustrations may include optional equipment and accessories, and may not include all standard equipment.

PACKING LIST

The ECHO product you purchased has been factory pre-assembled for your convenience. Due to packaging restrictions, guide bar and saw chain installation and other assembly may be necessary.

After opening the carton, check for damage. Immediately notify your retailer or ECHO Dealer of damaged or missing parts. Use the contents list to check for missing parts.

CONTENTS

- 1 - CS-330T Power Head
- 1 - Guide Bar
- 1 - Kick Guard
- 1 - Hex Head Bolt
- 1 - Hex Nut
- 1 - Saw Chain
- 1 - Instruction Manual
- 1 - Safety Manual
- 1 - Emission Control Warranty Statement
- 1 - Warranty Registration Card
 - Assembly Tool (s)
- 1 - Echo Power BlendX™ 2-stroke oil sample



RULES FOR SAFE OPERATION

1. Fatigue causes carelessness. Be more cautious before rest periods and before the end of your shift.
2. Personal protective clothing required by your safety organizations, government regulations, or your employer should be used; otherwise, sun fitting clothing, protective eyewear, safety footwear and hand, leg and hearing protection should be worn.

Note: Personal protective clothing should meet the requirements of applicable Standards.

3. Before fueling, servicing or transporting your chain saw switch off the engine. To help prevent fire, restart your chain saw at least 3 m from the fueling area.
4. When using a chain saw a fire extinguisher should be available.
5. When felling, keep at least 2 tree lengths between yourself and your fellow workers.
6. Plan your work; assure yourself of an obstacle-free work area and, in the case of felling, of an escape path from the falling tree.
7. Follow instructions in your operator's manual for starting the chain saw and control the chain saw with a firm grip on both handles when it is in operation. Keep handles dry, clean and free of oil. A chain saw should never be carried with the engine running.
8. When transporting your chain saw, use the appropriate transportation covers that should be available for the guide bar and saw chain.
9. Never operate a chain saw that is damaged, improperly adjusted, or is not completely and securely assembled. Be sure that the saw chain stops moving when the throttle control trigger is released. Never adjust the guide bar or saw chain when the engine operating.
10. Beware of carbon monoxide poisoning. Operate the chain saw in well-ventilated areas only.
11. Do not attempt a pruning or liming operation in a standing tree unless specifically trained to do so.
12. Guard against kickback. Kickback is the upward motion of the guide bar, which occurs when the saw chain, at the nose of the guide bar, contact an object. Kickback can lead to dangerous loss of the chain saw.

TO AVOID KICKBACK:

- (a) Contact of the guide bar tip with any object should be avoided.
 - (b) Tip contact may cause the guide bar to move suddenly upward and backward which may cause serious injury.
 - (c) Always use two hands when operating the chain saw.
 - (d) Use a firm grip, thumbs and fingers encircling the handles.
 - (e) Don't overreach.
 - (f) Avoid cutting above shoulder height.
 - (g) Follow the manufacture's instructions for sharpening and maintenance of the saw chain.
13. When boring with the chain saw, the initial cut should be introduced with the lower part of the nose (tip) until the hole is sufficiently large so as to introduce the entire nose (tip) of the guide bar. This technique should reduce the danger of kickback.

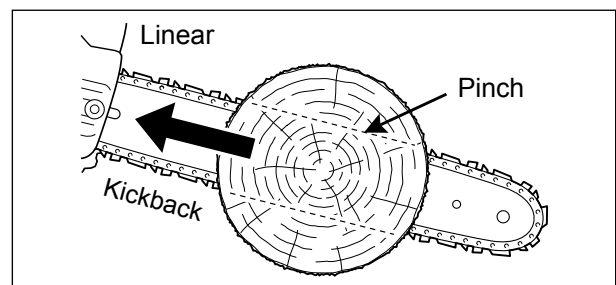
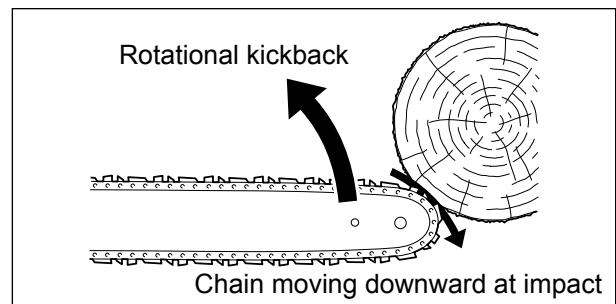
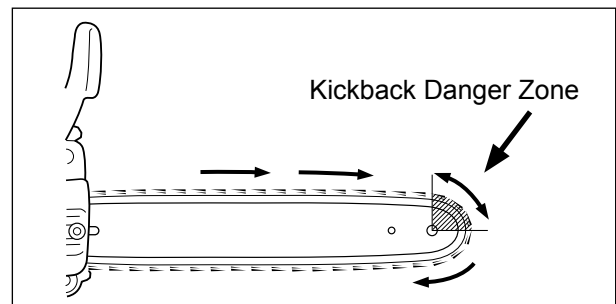
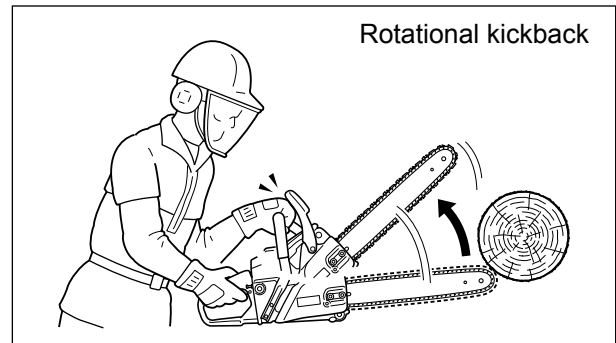

14. A chain saw is intended for two-handed use. Serious injury to the operator, helpers and/or bystanders may result from one-handed operation.

CAUTION

- A. Allow your chain saw to cool before refueling, and do not smoke while refueling.
- B. Do not allow other persons or animals close to running chain saw or close to where a tree is being felled.
- C. Use extreme caution when cutting small size brush and saplings because slender material may catch the saw chain and be whipped toward you.
- D. When cutting a limb that is under tension be alert for spring-back.

CORRECT USE OF CHAIN BRAKE

Chain brake function

When the lever is pushed forward, chain brake instantly stops the chain.

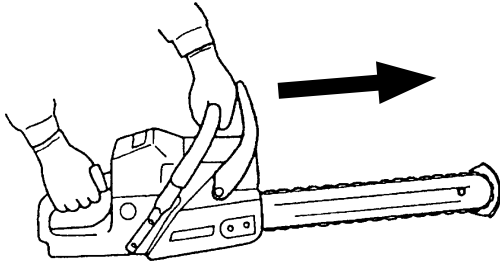

Chain brake unlock

When the lever is fully pulled, toward the operator, brake is unlocked.

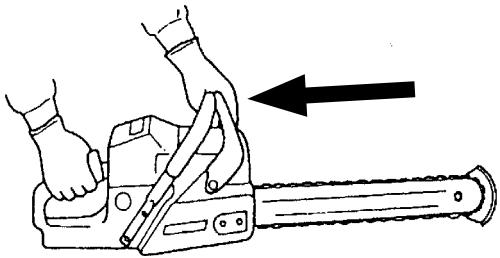

The installation of a chain brake may be mandatory by law or as stipulated by insurance regulations in your area of operation. You should inquire through local government offices, your employer or your local dealer to ensure that your chain saw conforms to the required safety standard.

ECHO chain brakes have been designed and tested to comply with international safety standards as follows.

USA : ANSI Standard B175.1
Safety Requirement for chain saws

Canada : CSA Standard Z62.1, Z62.3 CHAIN
SAWS

WARNING

CSA Standard **CSA Z 62.1** stipulates that the brake shall stop the chain 0.12 seconds at an engine speed of 13500 r/min. It is the responsibility of the owner/operator to ensure that the brake is serviced, adjusted and tested strictly in accordance with the instructions as detailed herein in order to ensure that the brake performance is maintained in compliance with the Standard **CSA Z 62.1**

CHAIN BRAKE OPERATION

- Set the lever in the unlocked position before starting to cut.
- If the brake is tripped by kickback reaction, the chain will stop immediately. Release the throttle to avoid possible damage to the engine or clutch.
- Do not attempt to operate the engine with the brake locked.

TESTING THE BRAKE

- Start the engine on a solid level surface and run at a fast idle until warm.
- Hold the saw firmly by the handles and accelerate the engine to a fast idle.
- Slowly operate the chain brake lever while holding the saw firmly on the ground. When the brake lever trips, the chain should stop. Immediately release the throttle trigger.

IMPORTANT

Do not allow the saw to tip forward in order to avoid damage to the chain.

WARNING

If the chain does not stop immediately, return the saw to your authorized ECHO dealer for repair.

NOTE

- For practice, while cutting a small tree, push the lever forward to lock the brake.
- Confirm that the brake works properly before each use.
- If the chain brake is clogged with wood chips, function of the brake may deteriorate. Always keep the device clean.
- Do not increase engine RPM's while the chain brake is locked.



WARNING

- During operation, the muffler or catalytic muffler and surrounding cover become hot.
- Never suspend the saw on a lanyard with the engine running.
- Always use the saw from the right-hand side of your body – **NEVER** from the left side.
- Always wear proper safety clothing to protect your lower body from sharp saw chain and hot muffler.
- Always keep exhaust area clear of flammable debris during transportation or when storing, otherwise serious property damage or personal injury may result.



WARNING

Using improper replacement components or removing safety devices may result in serious or fatal injury.



WARNING

Moving parts can amputate fingers or cause severe injuries. Keep hands, clothing and loose objects away from all openings.

- **ALWAYS** stop engine, disconnect spark plug, and make sure all moving parts have come to a complete stop before removing obstructions, clearing debris, or servicing unit.
- **DO NOT** start or operate unit unless all guards and protective covers are properly assembled to unit.
- **NEVER** reach into any opening while the engine is running. Moving parts may not be visible through openings.



WARNING

Check fuel system for leaks due to fuel tank damage, especially if the unit is dropped. If damage or leaks are found, do not use unit, otherwise serious personal injury or property damage may occur. Have unit repaired by an authorized servicing dealer before using.



WARNING

The ignition components of this machine generate an electromagnetic field during operation which may interfere with some pacemakers. To reduce the risk of serious or fatal injury, persons with pacemakers should consult with their physician and the pacemaker manufacturer before operating this machine. In the absence of such information, ECHO does not recommend the use of ECHO products by anyone who has a pacemaker.

OPERATOR SAFETY

VIBRATION AND COLD

- It is believed that a condition called Raynaud's Phenomenon, which affects the fingers of certain individuals, may be brought about by exposure to vibration and cold. Exposure to vibration and cold may cause tingling and burning followed by loss of color and numbness in the fingers. The following precautions are strongly recommended because the minimum exposure which might trigger the ailment is unknown.
- Keep your body warm, especially the head and neck, feet and ankles and hands and wrists.
- Maintain good blood circulation by performing vigorous arm exercises during frequent work breaks and also by not smoking.
- Limit the number of hours of operation. Try to fill each day with jobs where operating the chain saw, or other hand-held power equipment is not required.
- If you experience discomfort redness and swelling of the fingers, followed by whitening and loss of feeling, consult your physician before further exposing yourself to cold and vibration.

REPETITIVE STRESS INJURY

- It is believed that over-using the muscles and tendons of the finger, hands, arms and shoulders may cause soreness, swelling, numbness, weakness and extreme pain to the areas just mentioned. Certain repetitive hand activities may put you at a high risk for developing a repetitive stress injury (RSI).
- An extreme RSI condition is Carpal Tunnel Syndrome (CTS) which could occur when your wrist swells and squeezes a vital nerve that runs through the area. Some believe that prolonged exposure to vibration may contribute to CTS. CTS can cause severe pain for months or even years.

To reduce the risk of RSI/CTS, do the following:

- Avoid using your wrist in a bent, extended or twisted position.
- Take periodic breaks to minimize repetition and rest your hands.
- Reduce the speed and force in which you do the repetitive movement.
- Do exercises to strengthen hand and arm muscles.
- See a doctor if you feel tingling, numbness or pain in your fingers, hands, wrists or arms. The sooner RSI/CTS is diagnosed, the more likely permanent nerve and muscle damage can be prevented.

EYE AND HEARING PROTECTION

- Wear eye protection goggles that meet CSA Z 94.3 requirements. Goggles meeting the requirements have the mark "Z 94" stamped on them.
- Wear hearing protection.
If this guideline is not followed, hearing loss can occur. ECHO recommends wearing hearing protection at all times.

WEAR PROPER CLOTHING

- Snug fitting durable clothing should be worn. Pants should have long legs,
- **DO NOT WEAR SHORTS.** Do not wear loose fitting clothing, scarves, neckties, jewelry or any item that may become tangled in surrounding growth or the chain saw itself.
- Wear shoes with non-skid soles. **DO NOT** wear open toed shoes or operate unit barefooted.
- Wear no-slip, heavy duty work gloves to improve your grip on the chain saw handles. The gloves also help reduce the transmission of machine vibration to your hands.
- Keep long hair away from engine and air intake. Retain hair with cap or net.













HOT HUMID WEATHER

- Heavy protective clothing can increase operator fatigue which may lead to heat stroke. Schedule heavy work for early morning, or late afternoon hours when temperatures are cooler.

AVOID HOT SURFACES

- During operation, the muffler or catalytic muffler and surrounding cover become hot.
- Never suspend the saw on a lanyard with the engine running.
- Always use the saw from the right-hand side of your body - **NEVER** from the left side.
- Always wear proper safety clothing to protect your lower body from sharp saw chain and hot muffler.
- Always keep exhaust area clear of flammable debris during transportation or when storing, otherwise serious property damage or personal injury may result.

SYMBOLS AND SIGNS

Symbol form/shape	Symbol description/application	Symbol form/shape	Symbol description/application
	Read and understand Operator's Manual.		Chain oil fill
	Wear eyes, ears and head protection		Chain oil pump
	Chain brake operation		Chain oiler adjustment
	Emergency stop		Carburetor adjustment - Low speed mixture
	Choke control "Cold Start" position (choke closed)		Carburetor adjustment - High speed mixture
	Gasoline and oil mixture		Carburetor adjustment - Idle speed

DANGER

The safety alert symbol accompanied by the word "DANGER" calls attention to an act or condition which WILL lead to serious personal injury or death if not avoided.



CIRCLE AND SLASH SYMBOL

This symbol means the specific action shown is prohibited. Ignoring these prohibitions can result in serious or fatal injury.

WARNING

The safety alert symbol accompanied by the word "WARNING" calls attention to an act or condition which CAN lead to serious personal injury or death if not avoided.

NOTE

This enclosed message provides tips for use, care and maintenance of the unit.

CAUTION

The safety alert symbol accompanied by the word "CAUTION" calls attention to an act or condition which may lead to minor or moderate personal injury if not avoided.

IMPORTANT

The enclosed message provides information necessary for the protection of the unit.

DECALS

CS-330T

Caution: This saw shall be used only by certified tree service professionals. For safe operation, follow all safety precautions and instructions in operator's manuals. (Replacement manuals are available from your Echo dealer.)
Hold chain saw firmly with both hands.

WARNING

Chain brake must be unlocked before removing or installing clutch cover. Improper cover installation can result in serious injury and cause severe damage to saw.
Le frein du chaîne doit être désengagé avant d'enlever ou installer la couverture de embrayage. La couverture installée incorrectement peut avoir conséquence d blessures sérieuses et endommager la scie.

ATTENTION

Cette tronçonneuse doit être utilisée seulement par des professionnels de l'abattage. Par un travail en sécurité respectez toutes les règles de sécurité et les indications du manuel d'utilisation. (Le manuel d'utilisation est disponible chez votre agent ECHO.)
Tenez fermement la tronçonneuse des deux mains.

TO AVOID KICKBACK

- Contact of the guide bar tip with any object should be avoided.
- Tip contact may cause the guide bar to move suddenly upward and backward which may cause serious injury.
- Always use two hands when operating the chain saw.

REPLACEMENT BAR AND CHAIN
REPLACEMENT DU GUIDE ET DE LA CHAÎNE

GUIDE BAR P/NO.	CHAÎN TYPE	CKA
GUIDE PIECE NO.	TYPE DE CHAÎNE	
12" 12AOED3745	OREGON 91PX 45	17.8
14" 14AOED3752	OREGON 91PX 52	18.5
16" 16AOED3757	OREGON 91PX 57	18.3

CKA means Computed Kickback Angle.
CKA signifie angle de rebondissement calculé.

Note: There may other replacement components for achieving kickback protection. For details, please refer to the chain and bar combination sheets shown in the operator's manuals.
Remarque: Il y peut y avoir d'autres composants de remplacement qui protègent en cas de rebondissement. Pour plus de détails, se référer à la feuille sur les combinaison de guide de chaîne du manuel de l'utilisateur.

CAUTION/ATTENTION

Hearing protectors meeting the requirements of CSA Standard Z94.2 should be worn.
Les protecteurs auditifs pouvant être porter, doivent rencontrer les normes CSA Standard Z94.2.

POUR ÉVITER LES REBONDISSEMENTS

- Éviter tout contact entre le nez du guide-chaîne et un objet quelconque.
- Tout contact du nez peut provoquer un mouvement brusque vers le haut ou vers les bas et entraîner de graves blessures.
- Toujours employer les deux mains pour opérer la scie à chaîne.

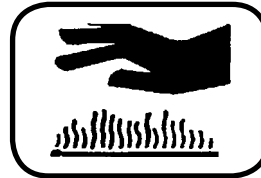

Locate these safety decals on your unit. Make sure the decals are legible and that you understand and follow the instructions on them. If a decal cannot be read, a new one can be ordered from your ECHO dealer.

EMISSION DATA

EMISSION CONTROL (EXHAUST & EVAPORATIVE)

EPA 2010 and Later

The emission control system for the engine is EM (engine modification) and, if the second to last character of the Engine Family on the Emission Control Information label (sample below) is "C", "K", or "T", the emission control system is EM and TWC (3-way catalyst). The fuel tank/fuel line emission control system is EVAP (evaporative emissions). Evaporative emissions for California models are only applicable to fuel tanks.

An Emission Control Label is located on the engine. (This is an EXAMPLE ONLY, information on label varies by engine FAMILY).

EMISSION CONTROL INFORMATION
ENGINE FAMILY: CEHXS.0214KQ DISPLACEMENT: 21.2cc
EMISSION COMPLIANCE PERIOD: 50hours
THIS ENGINE MEETS 2013 U.S. EPA EXH/EVP & CALIFORNIA EXH/EVP EMISSION REGULATIONS FOR S.O.R.E. REFER TO OWNER'S MANUAL FOR MAINTENANCE SPECIFICATIONS AND ADJUSTMENTS.
YAMABIKO CORP. MMM/YYYY

EMISSION CONTROL INFORMATION
ENGINE FAMILY: CEHXS.0214KL DISPLACEMENT: 21.2cc
EMISSION COMPLIANCE PERIOD: 300hours
THIS ENGINE MEETS 2012 U.S. EPA EXH/EVP & CALIFORNIA EXH/EVP EMISSION REGULATIONS FOR S.O.R.E. REFER TO OWNER'S MANUAL FOR MAINTENANCE SPECIFICATIONS AND ADJUSTMENTS.
YAMABIKO CORP. MMM/YYYY

PRODUCT EMISSION DURABILITY (EMISSION COMPLIANCE PERIOD)

The 50 or 300 hour emission compliance period is the time span selected by the manufacturer certifying the engine emissions output meets applicable emissions regulations, provided that approved maintenance procedures are followed as listed in the Maintenance Section of this manual.

NOMENCLATURE OF PARTS

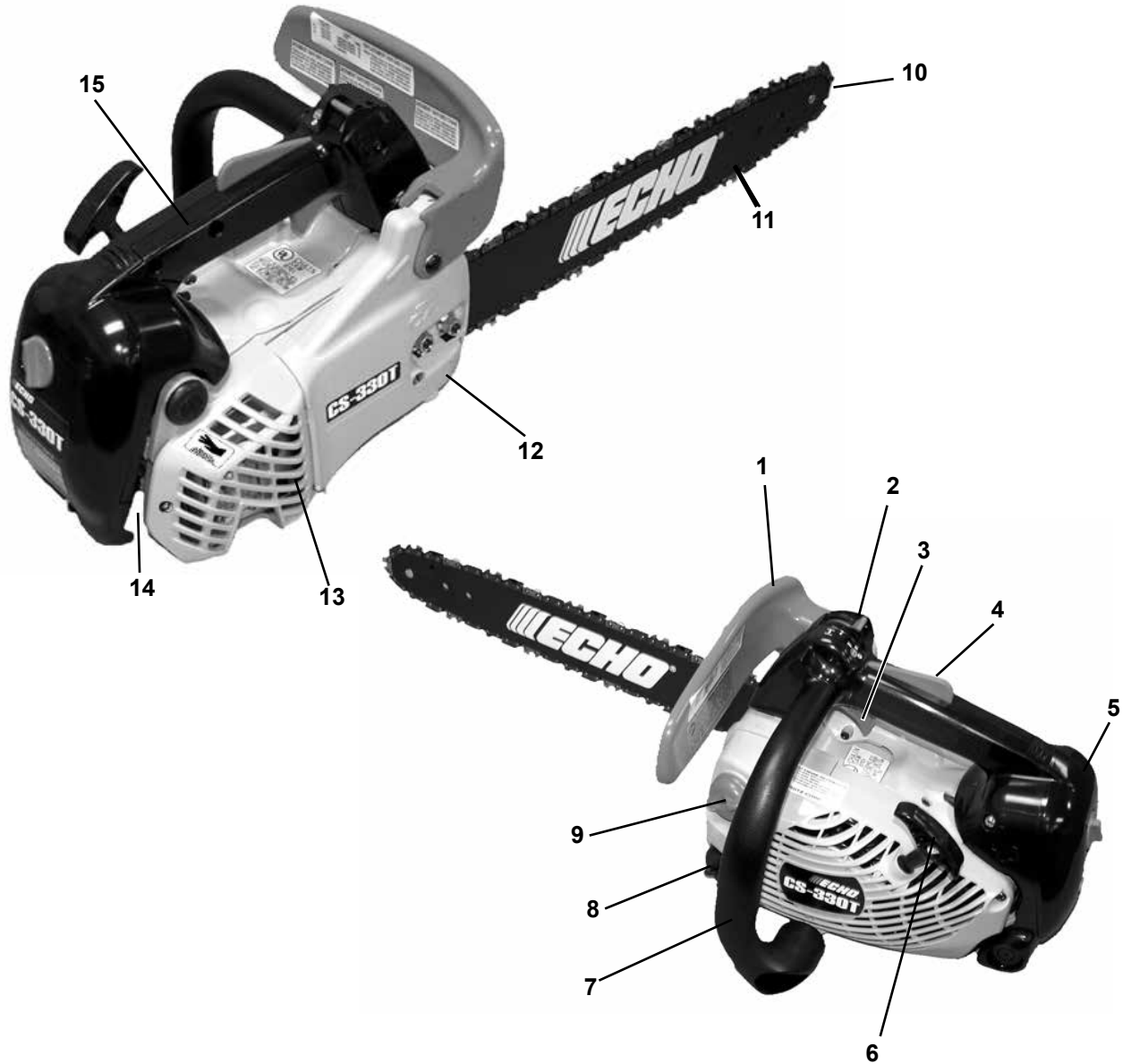

- 1. Chain brake actuating lever/
Hand guard
- 2. Ignition/Choke Lever
- 3. Throttle control trigger
- 4. Throttle control lockout

- 5. Air cleaner cover
- 6. Pull starter
- 7. Front handle
- 8. Oil tank cap

- 9. Fuel tank cap
- 10. Saw chain
- 11. Guide bar

- 12. Sprocket guard
- 13. Catalytic muffler
- 14. Spark Plug
- 15. Rear (Top) Handle

PREPARATION FOR USE

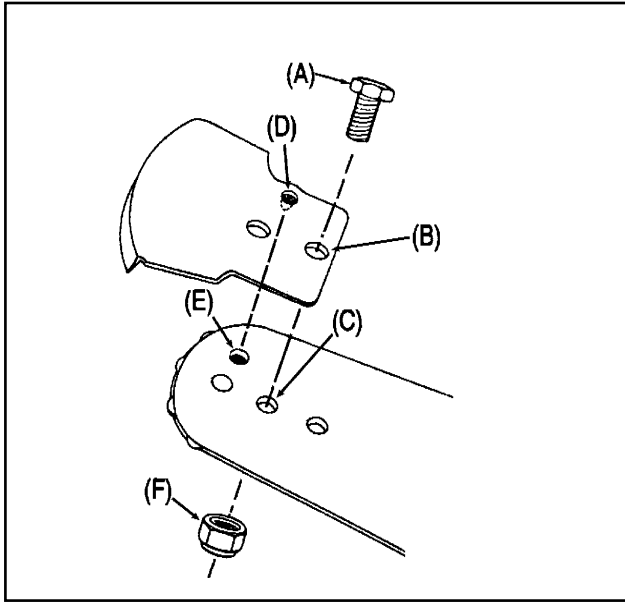

KICK GUARD® TO BAR INSTRUCTIONS

For saws with Kick Guard® P/N 2894901 and symmetrical or asymmetrical low-kick type guide bars.

1. Install bolt (A) in **rear** hole (B) of Kick Guard® and through front hole (C) in guide bar.
2. **IMPORTANT:** Dimple in Kick Guard® (D) must engage recess in guide bar (E).
3. Tighten nut (F) and bolt (A) until snug. Make certain Kick Guard® is flush against guide bar.

GUIDE BAR AND SAW CHAIN-INSTALL/ REMOVE



WARNING

Saw Chain is sharp! Always wear gloves when handling assembly, otherwise serious personal injury may result.

1. Move chain brake lever (G) fully rearward to unlock chain brake.

IMPORTANT

Always loosen guide bar nuts before turning chain tension adjuster, otherwise clutch cover and tensioner will be damaged.

2. Remove two guide bar nuts (H). Turn tension adjustment screw (J) counterclockwise 2 to 3 turns if bar and chain are installed.
3. Push clutch cover (K) forward, pull rear of cover out slightly, then remove.
4. Remove guide bar and saw chain if necessary.

NOTE: See "MAINTENANCE AND CARE"

instructions for guide bar, sprocket, and saw chain maintenance.

5. Mount guide bar (L) on studs, and slide toward sprocket to make saw chain installation easier. Install saw chain (M) over clutch and place around sprocket and guide bar as shown, with cutters on top of guide bar facing forward.
6. Align holes of clutch cover (K) with guide bar studs, and tensioner pin (N) with lower guide bar adjuster hole. Install cover, then press and hold rear of cover to fully seat. Tighten guide bar nuts finger tight.

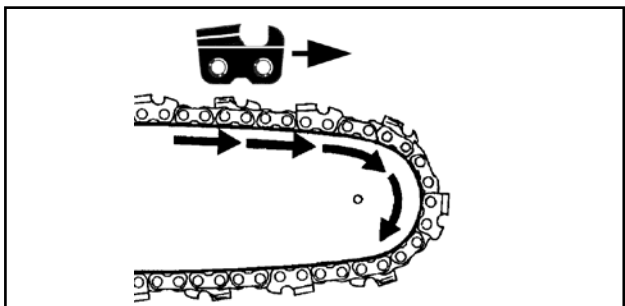
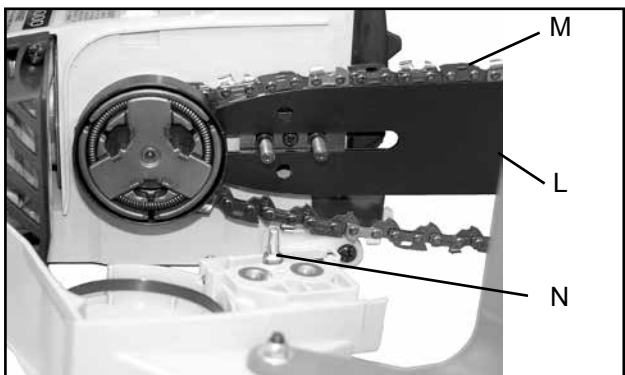
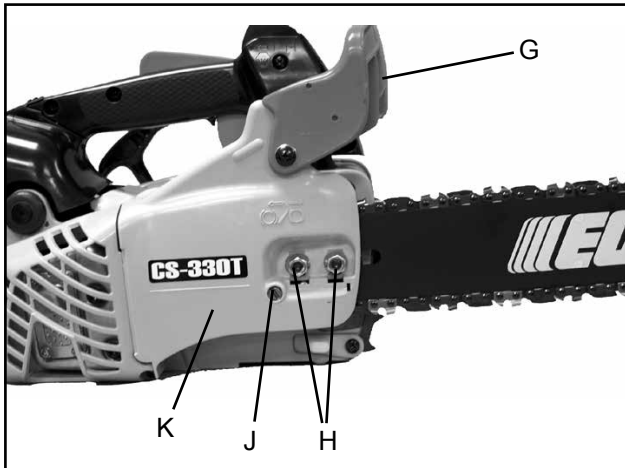

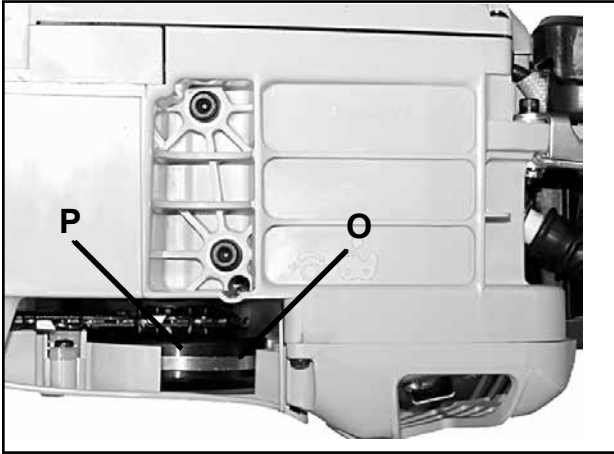

- Turn saw over and check brake band (O) for correct position around clutch drum (P). If brake band is not in place around drum, remove clutch cover, make sure brake is released, and reinstall.

⚠ DANGER

Never operate saw if chain brake does not function properly, otherwise saw damage and serious personal injury could result. See “Testing the Brake” instructions.

- Adjust saw chain tension, as instructed in “Adjustment, Chain Tension”

ADJUSTMENT, CHAIN TENSION

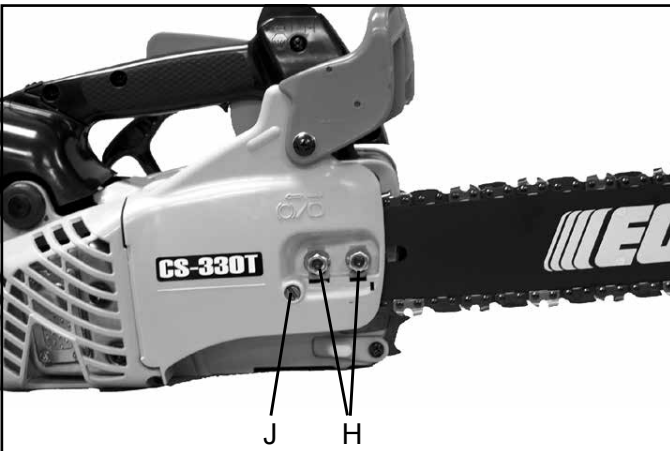

IMPORTANT

Always loosen guide bar nuts before turning chain tension adjuster, otherwise clutch cover and tensioner will be damaged.

- Remove air filter cover and spark plug lead.
- Loosen two guide bar nuts (H).
- Hold the bar nose up, and turn the adjuster screw (J) clockwise until the chain touches the bottom of the bar.
- Tighten both guide bar nuts with bar nose held up.



IMPORTANT!

Tighten guide bar nuts to 90 – 110 kgf/cm (80 – 95 in. lbs.) DO NOT over-tighten nuts. Damage to saw may result.

- Pull the saw chain around the guide bar by hand. Reduce chain tension, if you feel tight spots.

NOTE

All chains require frequent adjustments.

- Keep chain properly tensioned at all times.
- Replace spark plug lead and air filter cover.

FUEL AND LUBRICANT

NOTICE: Use of unmixed, improperly mixed, or fuel older than 90 days, (stale fuel), may cause hard starting, poor performance, or severe engine damage and void the product warranty. Read and follow instructions in the Storage section of this manual.

FUEL STATEMENT



WARNING

Alternative fuels, such as E-15 (15% ethanol), E-85 (85% ethanol) or any fuels not meeting ECHO requirements are **NOT** approved for use in ECHO 2-stroke gasoline engines. Use of alternative fuels may cause performance problems, loss of power, overheating, fuel vapor lock, and unintended machine operation, including, but not limited to, improper clutch engagement. Alternative fuels may also cause premature deterioration of fuel lines, gaskets, carburetors and other engine components.

Gasoline - Use 89 Octane [R+M/2] (mid grade or higher) gasoline known to be good quality. Gasoline may contain up to 10% Ethanol (grain alcohol) or 15% MTBE (methyl tertiary-butyl ether). Gasoline containing methanol (wood alcohol) is **NOT** approved.

Two Stroke Oil - A two-stroke engine oil meeting ISO-L-EGD (ISO/CD 13738) and J.A.S.O. FD Standards must be used. Echo brand premium Power Blend X™ Universal 2-Stroke Oil meets these standards. Engine problems due to inadequate lubrication caused by failure to use an ISO-L-EGD (ISO/CD 13738) and J.A.S.O. FD certified oil, such as Echo premium Power Blend X™, will void the two-stroke engine warranty.

IMPORTANT

Echo premium Power Blend X™ Universal 2-Stroke Oil may be mixed at 50:1 ratio for application in all Echo engines sold in the past regardless of ratio specified in those manuals.

Handling Fuel



WARNING

Fuel is VERY flammable. Use extreme care when mixing, storing or handling or serious personal injury may result.

- Use an approved fuel container.
- DO NOT smoke near fuel.
- DO NOT allow flames or sparks near fuel.
- Fuel tanks/cans may be under pressure. Always loosen fuel caps slowly allowing pressure to equalize.
- NEVER refuel a unit when the engine is HOT or RUNNING!
- DO NOT fill fuel tanks indoors. ALWAYS fill fuel tanks outdoors over bare ground.
- DO NOT overfill fuel tank. Wipe up spills immediately.
- Securely tighten fuel tank cap and close fuel container after refueling.
- Inspect for fuel leakage. If fuel leakage is found, do not start or operate unit until leakage is repaired.
- Move at least 3m (10 ft.) from refueling location before starting the engine.

Mixing Instructions

1. Fill an approved fuel container with half of the required amount of gasoline.
2. Add the proper amount of 2-stroke oil to gasoline.
3. Close container and shake to mix oil with gasoline.
4. Add remaining gasoline, close fuel container, and remix.

IMPORTANT

Spilled fuel is a leading cause of hydrocarbon emissions. Some states may require the use of automatic fuel shut-off containers to reduce fuel spillage.

Fuel Mix Chart
50:1

Fuel to Oil Mix - 50:1 Ratio			
U.S.		METRIC	
GAS	OIL	GAS	OIL
Gallons	Fl. oz.	Liter	cc.
1	2.6	4	80
2	5.2	8	160
5	13	20	400

After use

- DO NOT store a unit with fuel in its tank. Leaks can occur. Return unused fuel to an approved fuel storage container.

Storage - Fuel storage laws vary by locality. Contact your local government for the laws affecting your area. As a precaution, store fuel in an approved, airtight container. Store in a well-ventilated, unoccupied building, away from sparks and flames.

CHAIN LUBRICANT

Proper lubrication of the chain while in operation reduces friction between the chain and the guide bar to a minimum and assures a longer service life.

- Use bar and chain oil of high quality for this purpose.
- Do not use used or reclaimed oil to avoid various oiler problems.
- Use ECHO bar and chain oil.
- When ECHO bar and chain oil is not available: Use motor oil, etc.
- Use bar and chain oil of the following grades:
SAE NO. 30 in summer
SAE NO. 10 in winter or when cutting resinous trees.
- When refueling, also refill chain oil.

IMPORTANT

Stored fuel ages. Do not mix more fuel than you expect to use in thirty (30) days, ninety (90) days when a fuel stabilizer is added.

IMPORTANT

Stored two-stroke fuel may separate. ALWAYS shake fuel container thoroughly before each use.

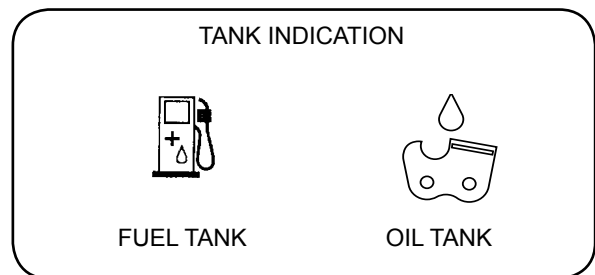

OPERATION



WARNING

Moving parts can amputate fingers or cause severe injuries. Keep hands, clothing and loose objects away from all openings. Always stop engine, disconnect spark plug, and make sure all moving parts have come to a complete stop before removing obstructions, clearing debris, or servicing unit.



WARNING

Engine exhaust IS HOT, and contains Carbon Monoxide (CO), a poison gas. Breathing CO can cause unconsciousness, serious injury, or death. Exhaust can cause serious burns. ALWAYS position unit so that exhaust is directed away from your face and body.



WARNING

Operation of this equipment may create sparks that can start fires. This unit is equipped with a spark arrestor to prevent discharge of hot particles from the engine. Metal blade use also can create sparks if the blade strikes rocks, metal, or other hard objects. Contact local fire authorities for laws or regulations regarding fire prevention requirements.

IMPORTANT

This saw features a combination ignition/choke switch that automatically sets the throttle speed to fast idle for quick starting. Do not squeeze trigger during cold starts until after unit has started, or fast idle and choke settings will be released, and engine may not start.

STARTING COLD ENGINE



WARNING

Make sure bar and chain are not touching anything when starting the saw.

1. Move chain brake lever (E) fully forward to lock chain brake before starting.
2. Fill the fuel tank with fuel. Do not over fill.
3. Fill the chain oil tank with lubricant. Do not over fill.
4. Move ignition/choke lever (A) forward to “close choke” (I) position.
5. Lay unit on a flat, clear area and keep bar and chain clear of all obstacles. Hold top handle with one hand, and depress throttle trigger lockout (C), but do not depress throttle trigger (D).
6. Pull starter handle (F) several times until engine starts, or first starting sound is heard. (7 pulls maximum)



WARNING

- After choke lever is moved to run position, throttle remains slightly open (fast idle latch condition).
- The chain will attempt to move when engine is started with fast idle throttle latch engaged.
- Do not start engine before chain brake is locked.

NOTE

Do not pull starter rope out to the maximum possible position. Do not allow recoil handle to snap back against the casing.

7. Move ignition/choke lever back to “run” (I) position (B). (Do not move to “Stop” position [G].) If necessary, start the engine.

NOTE

If engine does not start after 3 pulls with choke in “run” (I) position, repeat cold start instructions 4-7.

CAUTION

- After starting the engine, wait 5 seconds, then squeeze and release throttle trigger (D) to release fast idle throttle latch, otherwise severe brake damage may occur.
- Never use fast idle throttle latch for cutting.
- Use the fast idle throttle latch only in starting.

8. Allow unit to warm up at idle for several minutes.

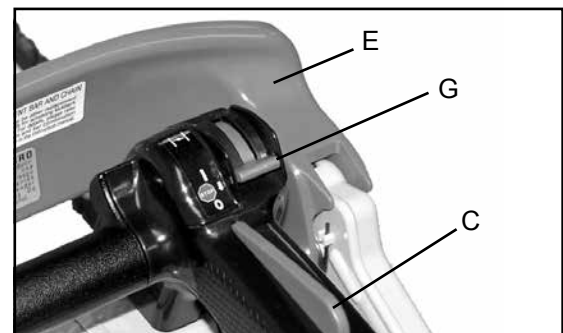
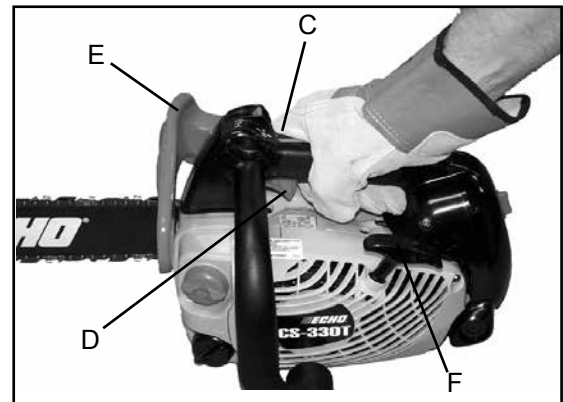
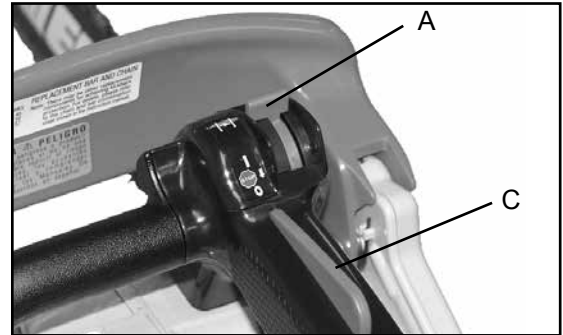

NOTICE

Do not increase engine speed while chain brake is locked. Severe brake damage will result.

STARTING WARM ENGINE

1. Ensure that there is fuel and chain oil in the tanks.
2. Move chain brake lever (E) fully forward to lock chain brake before starting.
3. Lay unit on a flat, clear area and keep bar and chain clear of all obstacles. Hold top handle with one hand, and depress throttle trigger lockout, but do not depress throttle trigger.
4. Move ignition/choke lever (A) forward to "Run" position (I).
5. Pull starter handle.

NOTE

If engine does not start after 5 pulls, use cold start procedure.

NOTICE

Do not increase engine speed while chain brake is locked. Severe brake damage will result.

RUNNING



WARNING

The saw chain should not move at idle, otherwise serious personal injury may result.

NOTE

If saw chain moves, adjust carburetor according to "Carburetor Adjustment" instructions in this manual, or see your dealer.

- After engine starts, allow it to return to idle and warm up before using.
- Move chain brake lever fully rearward to unlock chain brake.
- Press throttle control lockout then gradually squeeze throttle trigger to increase engine speed.
- Saw chain starts moving when the engine reaches approximately 4,300 rpm.
- Ensure proper acceleration and lubrication of chain and bar.
- Do not run the engine at high speed unnecessarily.
- Be sure that saw chain stops moving when throttle trigger is released.

STOPPING

1. Release throttle trigger (D) and move lever (A) rearward to STOP (O) position.
2. Move chain brake lever (E) fully forward to lock chain brake.

NOTE

If engine does not stop, move ignition/choke lever forward to choke position (I) to stop engine. Return the unit to your authorized ECHO dealer to check and repair stop switch before starting the engine again.

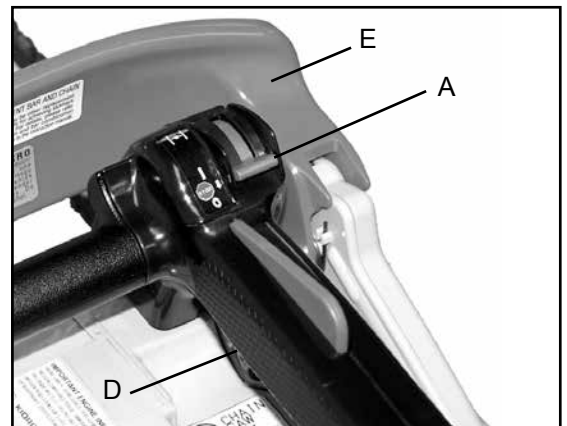
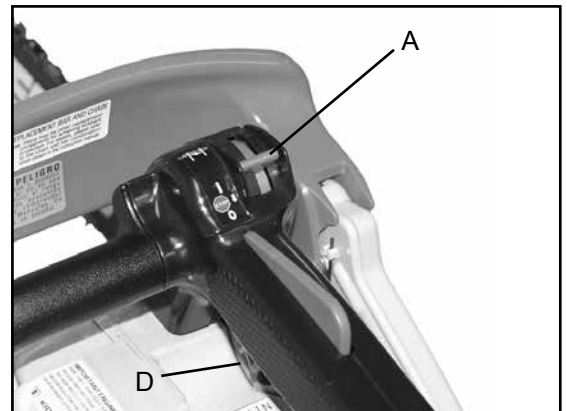
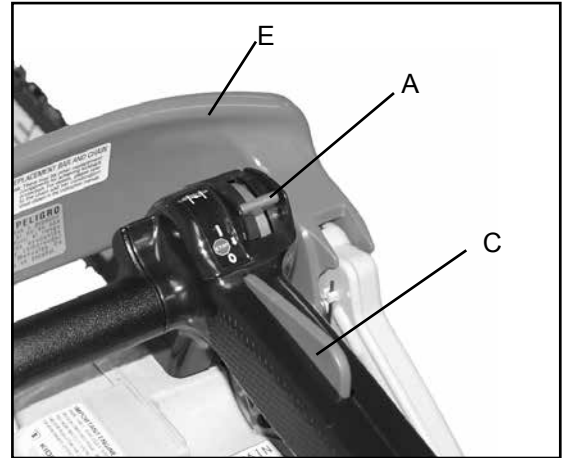

CUTTING INSTRUCTIONS

GENERAL

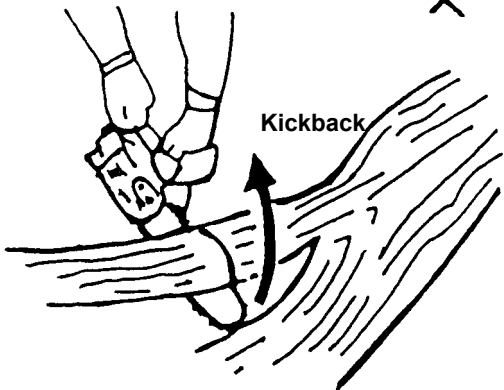
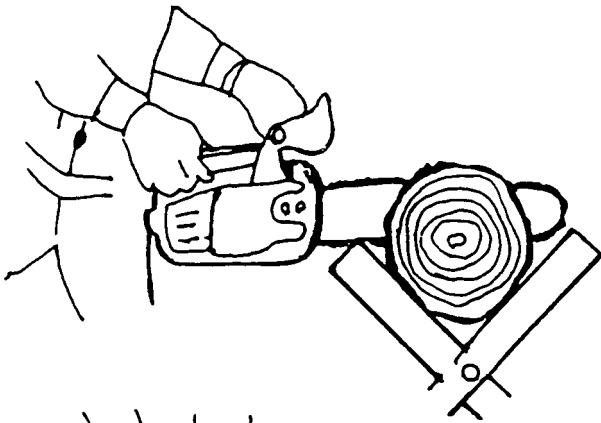
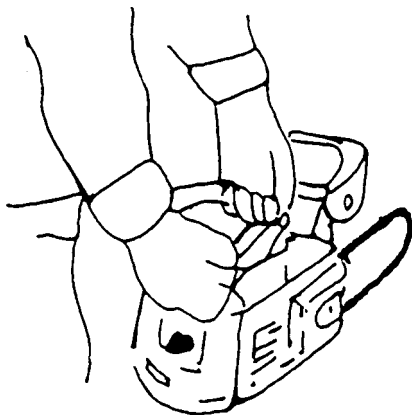
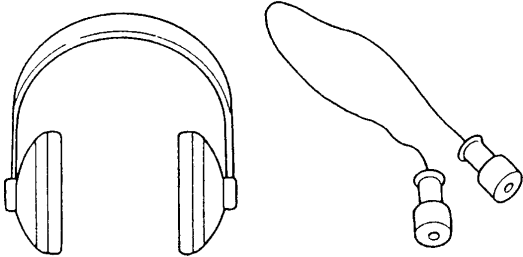

WARNING

Read the ECHO "CHAIN SAW SAFETY MANUAL" included with your chain saw for additional cutting and safety instructions. Failure to obey all instructions may result in serious or fatal injuries.

In all circumstances the operation of the chain saw is a one-man job. It is difficult at times to take care for your own safety, so don't assume the responsibility for a helper as well. After you have learned the basic techniques of using the saw, your best aid will be your own good common sense...

The accepted way to hold the saw is to stand to the left of the saw with your left hand on the front handlebar and your right hand on the rear handle so you can operate the throttle trigger with your right index finger.

Before attempting to fell a tree, cut some small logs or limbs. Become thoroughly familiar with the controls and the responses of the saw.

Start the engine, see that it is running properly. Squeeze the trigger to open the throttle wide open and start the cut. If the chain is properly sharpened, the cutting should be relatively effortless. It is not necessary to press down hard to make the saw cut. Pushing the saw too hard will slow the engine and cutting will actually be more difficult.

NOTE

Some material may adversely affect the housings of your ECHO chain saw.

(Example: Palm Tree Acid, fertilizer, etc.) To avoid housing deterioration, carefully remove all packed saw dust around clutch and guide bar area and wash with water. Coat metal parts with light oil.



WARNING

Do not let the tip of the bar touch anything while the engine is running. At cutting speed the chain is moving at a high rate of speed. Should the tip contact a limb or log while the chain is moving, the tip will be pushed upward with considerable force. This is known as kickback. Avoid it!

FELLING A TREE

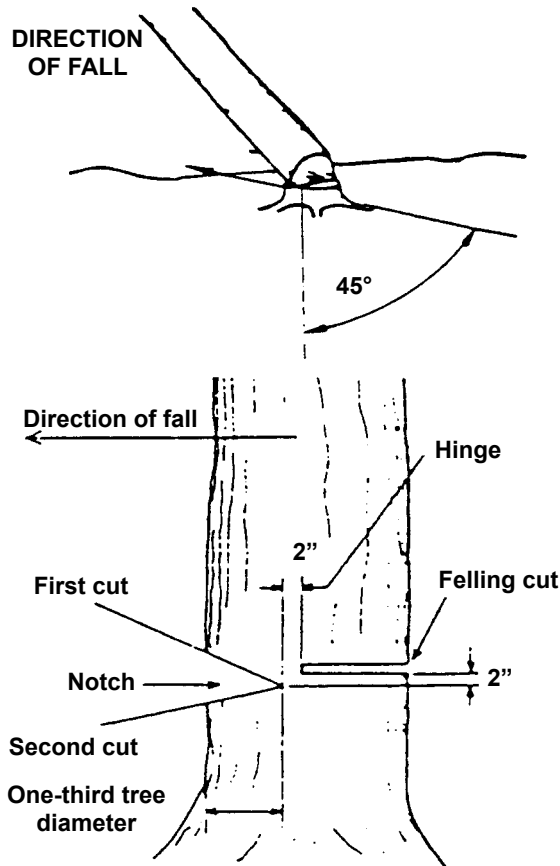

WARNING

A falling tree can seriously damage anything it may hit - a car, a house, a fence, a power line, or another tree. There are ways to make a tree fall where you want it, so first decide where that is!

Before cutting, clear the area around the tree. You will need good footing while working and you should be able to work the saw without hitting any obstacles. Next, select a path of retreat. When the tree begins to fall you should retreat away from the direction of fall at a 45 degree angle and at least 3m from the trunk to avoid the trunk kicking back over the stump.

Begin the cut on the side to which the tree is to fall. Cut a notch about 1/3 of the way into the tree as shown. The position of this notch is important since the tree will try to fall "into" the notch. The felling cut is made on the side opposite the notch and at a level about 2" above the bottom of the notch. Do not try to cut through to the notch with the felling cut. The remaining wood between the notch cut and felling cut (about 2") will act as a hinge when the tree falls, guiding it in the desired direction. When the tree starts to fall, kill the engine, place the saw on the ground and make your retreat quickly.

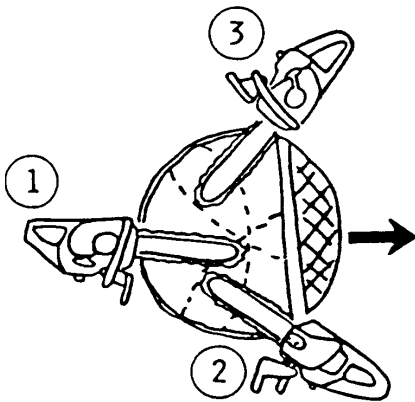

To fell big trees with a diameter exceeding twice the bar length, start the notching cuts from one side and draw the saw through to the other side of the notch. Start the back cut on one side of the tree, pivoting the saw through to form the desired hinge on that side.

Then remove the saw for the second cut. Insert the saw in the first cut, very carefully so as not to cause kickback. The final cut is made by drawing the saw forward in the cut to reach the hinge.

LIMBING

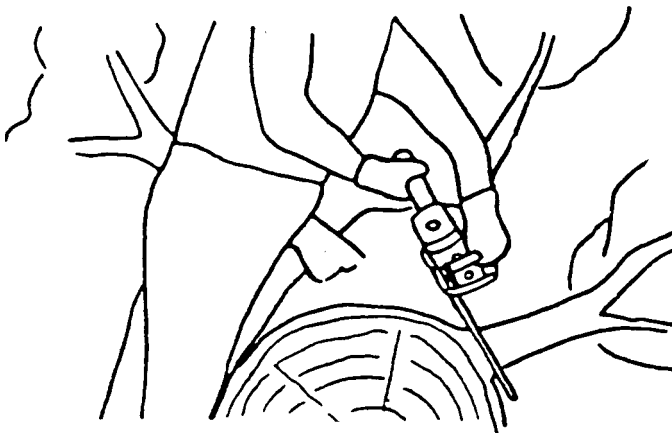

Limbing a fallen tree is much the same as bucking. Never limb on the tree that you are standing. When limbing, caution is the word. Be careful of the tip touching other limbs. Always use both hands.



Don't cut with the saw overhead or the bar in a vertical position. If the saw should kick back you may not have good enough control to prevent possible injury.

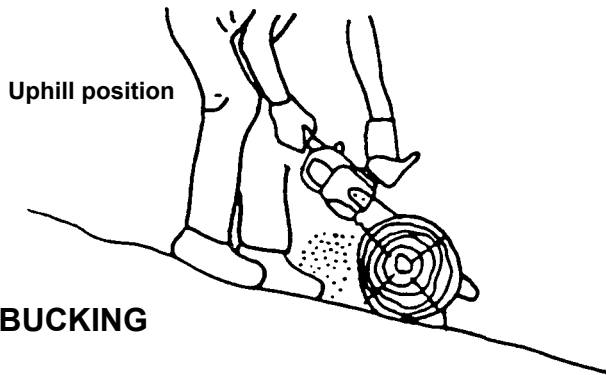

Bucking is the sawing of a log or fallen tree into smaller pieces. There are a few basic rules which apply to all bucking operations.

Keep both hands on the handles at all times.

Support logs if possible.

When cutting on a slope or hillside, always stand uphill.

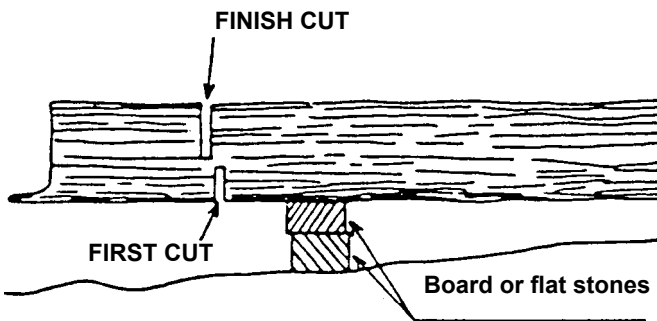

Keep in mind that the wood is heavy and that it will bend and pinch the saw if improperly supported.

The trunk will weaken at the point where you make the cut unless the tree is lying on perfectly flat ground or supported as shown.

If you make the cut with the tree on the ground, don't let the saw's chain dig into the earth; it is harmful for the saw, and you stand a good chance of being struck by flying debris. To cut the trunk, use the bucking and two-cut sequence shown. The first cut should be no deeper than one-third the trunk diameter.

CHAIN AND GUIDE BAR COMBINATIONS

The following combinations may be used on CS-330T.

MODEL	BAR LENGTH	LOW KICKBACK GUARD BAR	LOW KICKBACK SAW CHAIN					KICK GUARD
		BAR P/N	CHAIN PART NO.	LINKS	TYPE	PITCH	GAUGE	ECHO P/N (OEM P/N)
CS-330T	12"	12A0ED3745	91PX-45 91VG-45	45	91PX 91VG	3/8"	0.050	2894901 28949
	14"	14A0ED3752	91PX-52 91VG-52	52				
	16"	16A0ED3757	91PX-57 91VG-57	57				

*Reduced nose radius symmetrical bars (OREGON name — Double Guard)



WARNING

Use of replacement saw chain and/or guide bar other than that specified, or operation without the “tip guard” in place, may cause severe kickback resulting in serious injury.

Only use saw chain designated as, “LOW-KICKBACK,” that meets CSA Z62.1, Z62.3 Standards when tested on the representative sample of chain saws below 3.8 C.I.D., and the Echo guide bar specified.

IMPORTANT

Chain and guide bar gauge size must be identical. Use Bar/Chain combinations shown in table above.

IMPORTANT

If your kick guard is damaged or lost, contact your Echo dealer for a replacement. For the name of the Echo dealer nearest you, Call: 1-800-432-ECHO (3246) or on the web at www.echo-usa.com.

Refer to your Chain Saw Safety Manual for kick guard application information.

GUIDE BAR

(Low-kickback)

Replacement guide bars.

The following guide bars may be considered to have equivalent kickback energy.

- Sprocket nose guide bars of the same length and nose radius, same pitch and having the same number of teeth.
- Hard nose guide bars of the same length and nose radius as a sprocket nose bar.

SAW CHAIN

(Low-kickback)



CAUTION

Do not use replacement saw chain unless it has been designated as meeting the **CSA Z62.1, Z62.3** kickback performance requirements.

NOTE

LOW KICKBACK SAW CHAIN meets the kickback performance requirements of CSA Z62.1, Z62.3(safety requirements for gasoline-powered chain saws).

MAINTENANCE AND CARE



WARNING

Moving parts can amputate fingers or cause severe injuries. Keep hands, clothing and loose objects away from all openings. Always stop engine, disconnect spark plug, and make sure all moving parts have come to a complete stop before removing obstructions, clearing debris, or servicing unit. Allow unit to cool before performing service. Wear gloves to protect hands from sharp edges and hot surfaces.

Your ECHO unit is designed to provide many hours of trouble free service. Regular scheduled maintenance will help your unit achieve that goal. If you are unsure or are not equipped with the necessary tools, you may want to take your unit to an ECHO Service Dealer for maintenance. To help you decide whether you want to DO-IT-YOURSELF or have the ECHO Dealer do it, each maintenance task has been graded. If the task is not listed see your Echo dealer for repairs.

SKILL LEVELS

Level 1 = Easy to do. Common tools may be required.

Level 2 = Moderate difficulty. Some specialized tools may be required.

ECHO offers **REPOWER™** Maintenance Kits and Parts to make your maintenance job easier.

MAINTENANCE INTERVALS

COMPONENT/ SYSTEM	MAINTENANCE PROCEDURE	REQ'D SKILL LEVEL	DAILY OR BEFORE USE	EVERY REFUEL	3 MONTHS OR 90 HOURS	YEARLY 600 HOURS
Air Filter	Inspect/Clean	1	I / C *		R *	
Automatic Oiler	Inspect/Adjust	1	I			
Oil Filter	Inspect/Replace	1	I		I/C *	
Fuel System	Inspect/Replace	1	I (1) *	I (1) *		
Fuel Filter	Inspect/Replace	1			I *	I / R *
Fuel Cap Gasket	Replace	1			I *	R
Guide Bar & Sprocket Nose	Inspect/Clean/Lubricate	1	I / C *	I		
Saw Chain	Inspect/Sharpen/Replace/ Tensioning	2	I *			
Sprocket	Inspect/Replace	2	I *			
Spark Plug	Inspect/Clean	1			I / C / R *	
Cooling System	Inspect/Clean	2	I / C			
Muffler Spark Arrestor	Inspect/Clean/Replace	2			I / C / R *	
Cylinder Exhaust Port	Inspect/Clean/Decarbon	2			I / C	
Recoil Starter Rope	Inspect/Clean	1	I / C *			
Screws/Nuts/Bolts	Inspect/Tighten/Replace	1	I *			

MAINTENANCE PROCEDURE LETTER CODES: I = INSPECT, R = REPLACE, C = CLEAN

IMPORTANT NOTE - Time intervals shown are maximum. Actual use and your experience will determine the frequency of required maintenance.

MAINTENANCE PROCEDURE NOTES:

(1) Low evaporative fuel tanks DO NOT require regular maintenance to maintain emission integrity.

* Replacement is recommended based on the finding of damage or wear during inspection.

CARBURETOR ADJUSTMENT

Engine Break-In

New engines must be operated a minimum duration of two tanks of fuel break-in before carburetor adjustments can be made. During the break-in period your engine performance will increase and exhaust emissions will stabilize. Idle speed can be adjusted as required.

High Altitude Operation

This engine has been factory adjusted to maintain satisfactory starting, emission, and durability performance up to 1,100 feet above sea level (ASL) (96.0 kPa). To maintain proper engine operation and emission compliance above 1,100 feet ASL the carburetor may need to be adjusted by an authorized ECHO service dealer.

IMPORTANT

If the engine is adjusted for operation *above* 1,100 feet ASL, the carburetor must be re-adjusted when operating the engine *below* 1,100 feet ASL, otherwise severe engine damage may result.

BEFORE MAKING ADJUSTMENTS:

- The correct spark plug must be clean and properly gapped.
- The air filter element must be clean and properly installed.
- The muffler spark arrestor screen and exhaust port must be clear of carbon.
- The standard bar and chain combination must be installed to the power head, and properly tensioned.



WARNING

When carburetor adjustment is completed, the saw chain should not move at idle, otherwise serious personal injury may result.

LOW ALTITUDE ADJUSTMENT

1. Start engine and run for several minutes to reach operating temperature.
2. Stop engine.
3. Start engine and turn the high-speed needle (A) rich (CCW) until the engine runs between 13,500 and 14,500 RPM. Then turn the low-speed needle (B) rich (CCW) until the engine does not hesitate when accelerated.

DO NOT REMOVE LIMITER CAPS!

4. Idle Speed Adjustment.
 - Turn "idle" speed adjustment screw (C) CW until the saw chain begins to move, then turn the screw CCW until saw chain stops moving. Turn screw CCW an additional 1/4 turn.
5. Accelerate to full throttle for 2-3 seconds to clear excess fuel from engine then return to idle. Accelerate to full throttle to check for smooth transition from idle to full throttle. If engine stops or stalls after full warm up return the unit to your authorized ECHO dealer for adjustment.

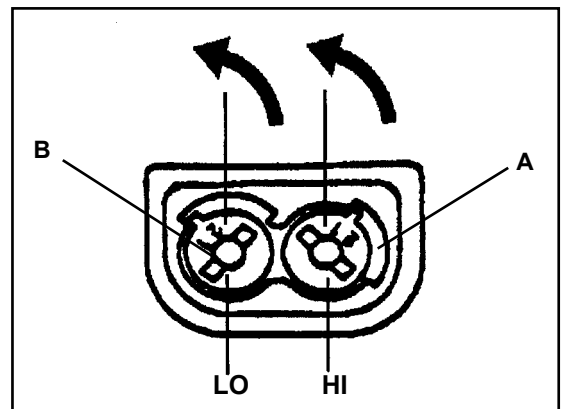
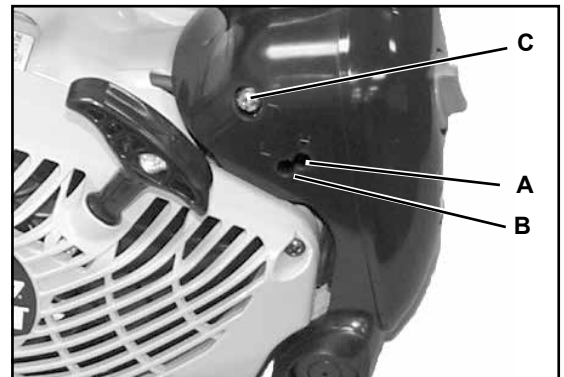

HIGH ALTITUDE ADJUSTMENT

1. Start engine and run for several minutes to reach operating temperature.
2. Stop engine.
3. Start engine and turn the HI speed needle (A) lean (CW) until the engine runs between 13,500 and 14,500 RPM. Then turn the LO speed needle lean (B) (CW) until the engine does not hesitate when accelerated.

DO NOT REMOVE LIMITER CAPS!

4. Idle Speed Adjustment.
 - Turn "idle" speed adjustment screw (C) CW until the saw chain begins to move, then turn the screw CCW until saw chain stops moving. Turn screw CCW an additional 1/4 turn.
5. Accelerate to full throttle for 2-3 seconds to clear excess fuel from engine then return to idle. Accelerate to full throttle to check for smooth transition from idle to full throttle. If engine stops or stalls after full warm up return the unit to your authorized ECHO dealer for adjustment.

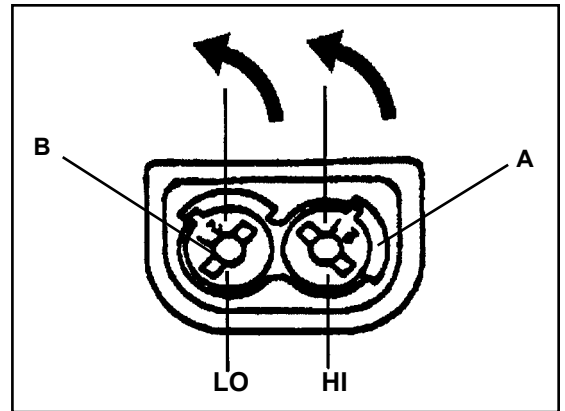
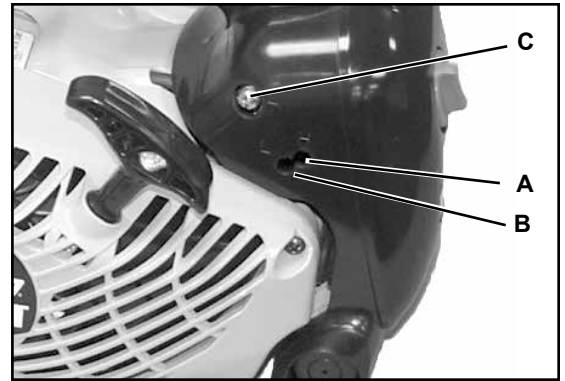

AIR FILTER

1. Close choke (Cold Start Position ). This prevents dirt from entering the carburetor throat when the air filter is removed. Brush accumulated dirt from air cleaner area.
2. Remove air filter cover. Brush dirt from inside cover.
3. Remove air filter and lightly brush debris from filter. Replace filter if it is damaged, fuel soaked, very dirty, or deformed.
4. Install air filter cover.



AUTOMATIC OILER

- The discharge volume of the automatic oiler is adjusted to 6 to 7 cc/min (@ 7000 rpm) prior to shipment from the factory.
- Always check oil discharge when in use.
- Turn adjusting screw (D) counter-clockwise to increase oil volume, clockwise to decrease oil volume.



OIL STRAINER

- Check periodically.
- 1. Do not allow dust to enter oil tank.
- 2. Clogged oil strainer will affect the normal lubricating system
- 3. Using a wire bent into the shape of a hook, pull strainer out through oil port and inspect strainer.
- 4. If the strainer is dirty, clean with suitable cleaning fluid.
- 5. If the inside of the oil tank is dirty, rinse with suitable cleaning fluid.
- 6. Install strainer into lower front of oil tank to ensure proper chain lubrication.



FUEL STRAINER

1. Do not allow dust to enter fuel tank.
2. Clogged strainer will cause difficulty in starting engine or abnormalities in engine performance.
3. Using a wire bent into the shape of a hook, pull strainer out through gas port, and inspect strainer.
4. If the strainer is dirty, clean with suitable cleaning fluid.
5. If the inside of the tank is dirty, rinse with suitable cleaning fluid.



NOTE

Federal EPA regulations require all model year 2012 and later gasoline powered engines produced for sale in the United States to be equipped with a special low permeation fuel supply hose between the carburetor and fuel tank. When servicing model year 2012 and later equipment, only fuel supply hoses certified by EPA can be used to replace the original equipment supply hose. Fines up to \$37,500 may be enforced for using an un-certified replacement part.

GUIDE BARS AND OIL HOLES

- Follow instructions for “Guide Bar and Saw Chain – Install/Remove”.
- Clean after each use
 - Clean the grooves (A) of the guide bar with a small screwdriver.
 - Clean oil holes (B) with a wire.

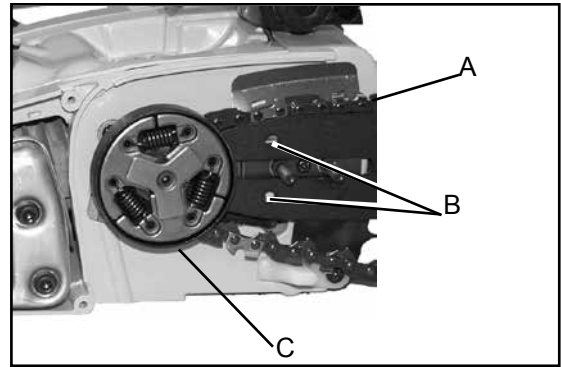

NOTE: Symmetrical shaped Guide Bars should be inverted each time the chain is removed to extend guide bar life.

SPROCKET

- A damaged sprocket (C) will cause premature damage or wear of saw chain.
- Clean sprocket, clutch and bar mount area before installation of bar.
- Check sprocket when you install new chain. When outer diameter of sprocket is worn 0.5mm (.020”) or more, replace it.

IMPORTANT

Some tree sap and resins are corrosive. Thoroughly wash the guide bar and sprocket areas after each use, then coat metal parts with light oil.

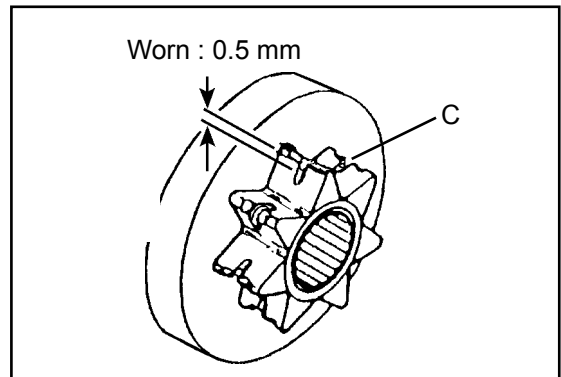

SPARK PLUG

- Check periodically.

IMPORTANT

Use only NGK BPM-8Y spark plug (BPMP-8Y in Canada) otherwise severe engine damage may occur.

1. Remove air cleaner cover.
2. Remove spark plug lead and spark plug.
3. Gap = 0.65 mm (0.026 in)
4. Replace if electrode is worn, or if the insulator is fouled by oil or other deposits
5. Torque = 150 – 170 kgf • cm (130 – 150 in • lbf)

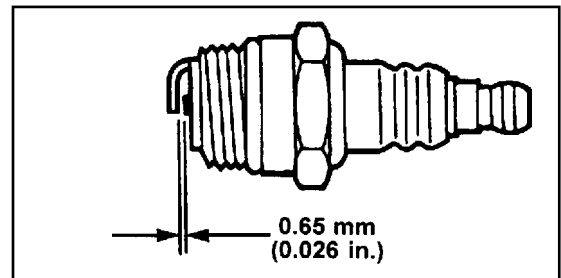

IMPORTANT

Do not over-torque

COOLING SYSTEM CLEANING

NOTE

See "Guide Bar and Saw Chain-Install/Remove Instructions for sprocket guard removal/replacement instructions.

Muffler Side

1. Remove air filter cover and remove spark plug lead.
2. Remove two guide bar nuts and remove sprocket guard.
3. Remove three muffler cover screws and remove muffler cover.
4. Using a stiff bristle cleaning brush (do not use a metal brush), remove debris from cylinder fins in muffler area.
5. Assemble components in reverse order.

Starter Side

1. Remove air filter cover and remove spark plug lead.
2. Remove plastic plug in side handle mount (D), and remove side handle mounting screw.
3. Remove four starter cover screws and remove starter cover.
4. Using a stiff bristle cleaning brush (do not use a metal brush), remove debris from flywheel and ignition coil area.
5. Assemble components in reverse order.

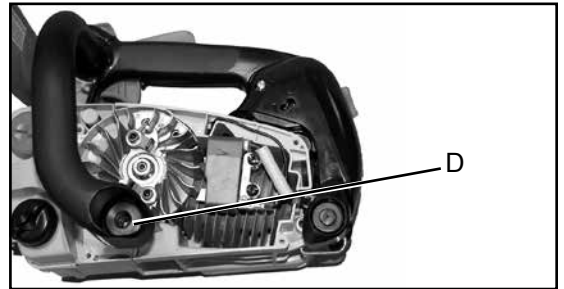

MUFFLER SPARK ARRESTOR

IMPORTANT

Carbon deposits in muffler will cause a drop in engine output and overheating. Spark arrestor screen must be checked periodically.

1. Remove air filter cover and remove spark plug lead.
2. Remove two guide bar nuts and remove sprocket guard.
3. Remove three muffler cover screws and remove muffler cover.
4. Remove spark arrestor screen cover, gaskets, and screen from muffler body.
5. Clean carbon deposits from muffler components.

NOTE

When cleaning carbon deposit, be careful not to damage the catalytic element inside muffler.

6. Replace screen if it is cracked, plugged, or has holes burned through.
7. Assemble components in reverse order.



Exhaust Port Cleaning

Parts Required: As needed: Muffler Gasket

1. Remove air filter cover and remove spark plug lead.
2. Loosen chain tension, release chain brake, and remove two guide bar nuts, clutch cover, guide bar, and chain.
3. Remove muffler cover screws and remove muffler cover. (See “Guide Bar and Saw Chain – Install/Remove” in Instruction Manual for detailed disassembly instructions.)

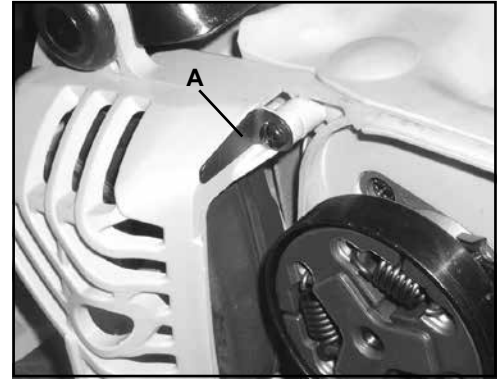

NOTE

Some units may have a metal shim (A) between the muffler cover and clutch cover. Make sure shim is installed properly when reassembling parts.

4. Place piston at top dead center.
5. Remove muffler nuts (B), washer sets (C), eyeplate (D), muffler (E), and muffler gasket (F). Check parts for wear or damage, and replace if necessary.
6. Use a wood or plastic scraping tool to clean deposits from cylinder exhaust ports (G).

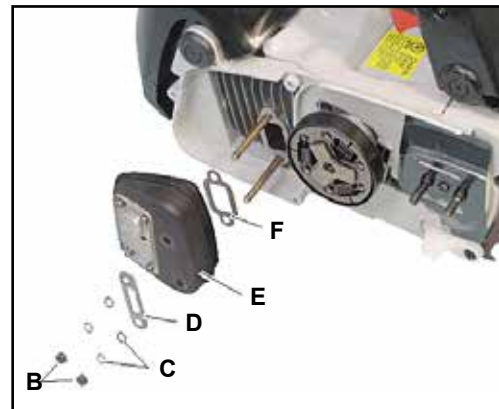

IMPORTANT

If muffler mounting studs loosened during muffler nut removal, tighten studs using two nuts (H) tightened together on end of stud. Turn outer nut clockwise, and tighten stud to 70 kgf • cm (7 N-m, 60 in • lbf). Do not exceed specifications, otherwise stud damage may occur. To remove nuts, hold inner nut, and turn outer nut counter clockwise to remove, then turn inner nut counter clockwise to remove.

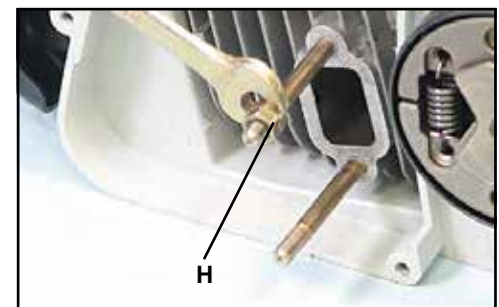

7. Install muffler gasket (F), muffler (E), eyeplate (D), washer sets (C), and muffler nuts (B). Tighten nuts to 70 kgf • cm (7 N-m, 60 in • lbf), but do not exceed specifications, otherwise damage to studs may occur.

IMPORTANT

Washer sets must be installed with serrated surfaces facing apart, as shown in illustration.

8. Connect spark plug lead and replace air filter cover.
9. Start engine, and allow unit to warm up **at idle** for several minutes.
10. Stop engine, and re-tighten mounting nuts to 70 kgf • cm (7 N-m, 60 in • lbf), but do not exceed specifications, otherwise damage to studs may occur.
11. Install muffler cover and tighten screws.
12. Install guide bar and chain, clutch cover, and guide bar nuts, tightening nuts until finger tight. Adjust chain tension as instructed in "Adjustment, Chain Tension" section of instruction manual.
13. Start engine and check for exhaust leaks between muffler and cylinder head. Stop engine if leak is found and correct problem before operating chain saw.

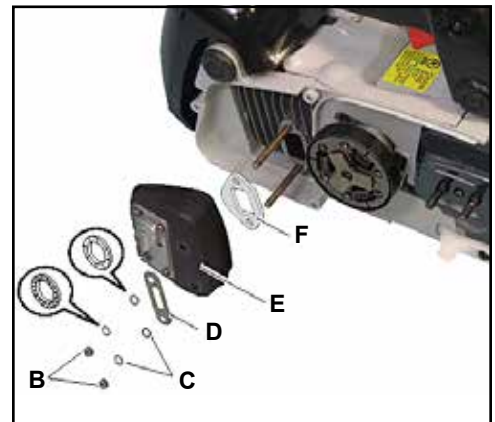

SETTING THE SAW CHAIN

For setting saw chains, round file (4 mm \varnothing : 5/32") and flat file are used.

- To keep correct position and correct angle, use the file holder.
- Round file and flat file are available from your Echo Dealer.

- File cutters as below.

To sharpen other type chain, follow chain manufacturer's instructions

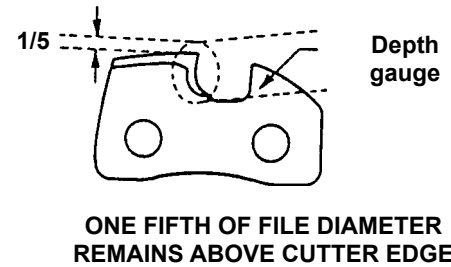
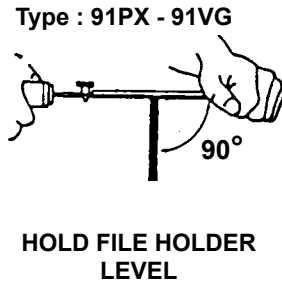
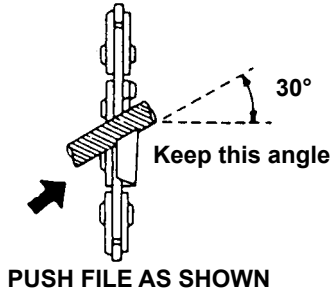

- Place the depth gauge tool firmly on guide bar so that depth gauge protrudes. Then file top of depth gauge with flat file until flat with top of the gauge tool.
- Be sure to round off the front edge of the depth gauge.

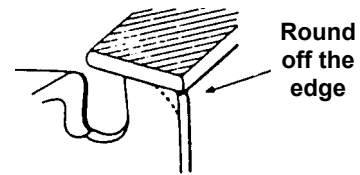
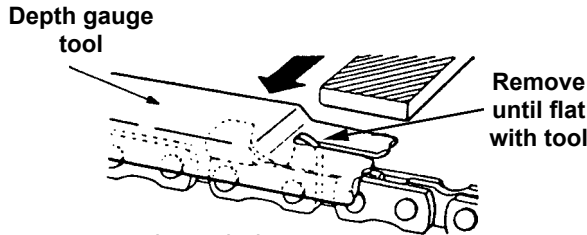

- Properly filed cutters are shown below.

(Top plate angle)

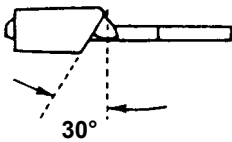

(Side plate angle)

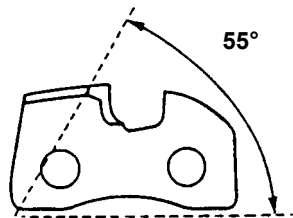

(Depth gauge)

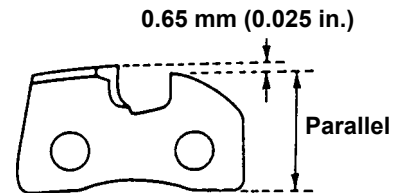

- When setting of the chain is finished, soak it in oil and wash away filings completely before using.
- When chain has been filed on the bar, supply sufficient oil to it, rotate the chain slowly to wash away the filings before using again.
- If the chain saw is operated with filings clogged in the groove, the saw chain and the guide bar will be damaged prematurely
- If the saw chain becomes soiled with resin, for instance, clean it with kerosene and soak it in oil.

CHAIN TYPE AND SPROCKET PITCH

Saw chain should be used with corresponding pitched sprocket. To identify chain type and pitch of sprocket, check as follows.

- Chain type number (A) is stamped on drive link.
- Sprocket pitch (B) is stamped on clutch drum.

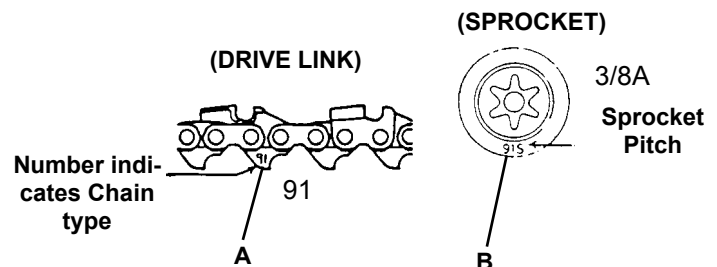

TROUBLESHOOTING

ENGINE PROBLEM TROUBLESHOOTING CHART				
Problem	Check	Status	Cause	Remedy
Engine cranks - starts hard/ doesn't start	Fuel at carburetor	No fuel at carburetor	Fuel strainer clogged Fuel line clogged Carburetor	Clean or replace Clean or replace See your Echo dealer
	Fuel at cylinder	No fuel at cylinder	Carburetor	See your Echo dealer
		Muffler wet with fuel	Fuel Mixture too rich	Open choke Clean/replace air filter Adjust carburetor See your Echo dealer
	Spark at end of plug wire	No spark	Stop switch off Electrical problem Interlock switch	Turn switch to ON See your Echo dealer See your Echo dealer
	Spark at plug	No spark	Spark gap incorrect Covered with carbon Fouled with fuel Plug defective	Adjust to .65mm (0.026 in.) Clean or replace Clean or replace Replace plug
Engine runs, but dies or does not accelerate properly	Air filter	Air filter dirty	Normal wear	Clean or replace
	Fuel filter	Fuel filter dirty	Contaminants/residues in fuel	Replace
	Fuel vent	Fuel vent plugged	Contaminants/residues in fuel	Clean or replace
	Spark Plug	Plug dirty/worn	Normal wear	Clean and adjust or replace
	Carburetor	Improper adjustment	Vibration	Adjust
	Cooling System	Cooling system dirty/plugged	Extended operation in dirty/dusty locations	Clean
	Spark Arrestor Screen	Spark arrestor screen plugged	Normal wear	Replace
Engine does not crank	N/A	N/A	Internal engine problem	See your Echo dealer



DANGER

Fuel vapors are extremely flammable and may cause fire and/or explosion. Never test for ignition spark by grounding spark plug near cylinder plug hole, otherwise serious personal injury may result.

STORAGE AFTER USE

- Inspect and adjust every part of the chain saw.
 - Completely clean every part and repair if necessary.
 - Apply thin coating of oil on metal parts to prevent rust.
- Remove chain and guide bar.
- Drain fuel tank completely. Press purge bulb 6 - 7 times to remove remaining fuel from carburetor then drain the tank again. Close choke, start and run the engine until it stops due to lack of fuel.
- Allow engine to cool then remove the spark plug and pour 7 cc (1/4 oz.) of fresh, clean, two-stroke engine oil into the cylinder through the spark plug hole.
- Store in a dry area, free from dust.



WARNING

Do not store in an enclosure where fuel fumes may accumulate or reach an open flame or spark.



CAUTION

Do not lend or rent your chain saw without the Instruction manual and Safety manual.

NOTE

- For future reference, you should keep this Instruction manual and the Safety manual.
- If this Instruction manual or the Safety manual has become illegible or is lost, please contact your ECHO dealer, or go to www.echo-usa.com.

TECHNICAL DATA

Model.....	CS-330T
Dimension L x W x H.....	277 x 247 x 214 mm (10.9 x 9.7 x 8.4 inch)
Weight Power head, dry.....	3.6 kg (7.9 lb) Without chain and guide bar
Engine	Type Air-cooled, two-stroke, single cylinder
	Displacement..... 32.6 cc (1.989 cu.in.)
	Carburetor..... Diaphragm type
	Magneto..... Flywheel magneto : CDI system
	Spark Plug NGK BPMR-8Y
	Starter..... Recoil starter
	Power transmission Automatic centrifugal clutch
Fuel.....	Mixture ratio 50 : 1 Power Blend X™ ISO-L-EGD (ISO/CD 13738) and J.A.S.O. M345- <u>FD</u> , two-stroke, air-cooled engine oil.
	Gasoline..... Use 89 Octane unleaded. Do not use fuel containing methyl alcohol, more than 10% ethyl alcohol or 15% MTBE. Do not use alternative fuels such as E-15 or E-85.
	Tank Capacity 310 ml (10.5 fl oz U.S.)
Oil	Power Blend X™ Premium Universal 2-Stroke Oil
	Bar and chain..... ECHO bar and chain oil (or motor oil)
	Tank Capacity 290 ml (9.8 fl. oz. U.S.)
	Lubrication Adjustable automatic oil pump
Guide bar / Saw chain	Standard 14 in
	Optional 12, 16in
Standard features	Top Handle Front hand guard, Anti-vibration device, Throttle control lockout, Chain catcher, Spark arrestor catalytic muffler
Idle Speed	2,600 RPM
Clutch Engagement.....	4,300 RPM
Wide Open Throttle (WOT).....	13,500 RPM
Kickback Safety Features.....	Double Guard Low Kick Guide Bar Low Kick Guard Link Saw Chain Front Hand Guard/Chain Brake Lever Chain Brake Kick Guard

* Technical data subject to change without notice.

IMPORTANT

This spark ignition system complies with the Canadian standard ICES-002.

WARRANTY STATEMENTS

ECHO LIMITED WARRANTY STATEMENT FOR PRODUCT SOLD IN USA AND CANADA BEGINNING 01/01/2010

ECHO'S RESPONSIBILITY

ECHO Incorporated's Limited Warranty, provides to the original purchaser that this ECHO product is free from defects in material and workmanship. Under normal use and maintenance from date of purchase, ECHO agrees to repair or replace at ECHO's discretion, any defective product free of charge at any authorized ECHO servicing dealer within listed below application time periods, limitations and exclusions. **THIS LIMITED WARRANTY IS ONLY APPLICABLE TO ECHO PRODUCTS SOLD BY AUTHORIZED ECHO DEALERS. IT IS EXTENDED TO THE ORIGINAL PURCHASER ONLY, AND IS NOT TRANSFERABLE TO SUBSEQUENT OWNERS EXCEPT FOR EMISSION RELATED PARTS.** Repair parts and accessories replaced under this warranty are warranted only for the balance of the original unit or accessory warranty period. Any damage caused by improper installation or improper maintenance is not covered by this warranty. All parts or products replaced under warranty become the property of ECHO, Inc. This warranty is separate from the Emission control warranty statement supplied with your new product. Please consult the Emission Control Warranty Statement for details regarding emission related parts. For a list of Authorized ECHO Dealers refer to WWW.ECHO-USA.COM or call 1-800-432-ECHO.

OWNER'S RESPONSIBILITY

To ensure trouble free warranty coverage it is important that you register your ECHO equipment on-line at WWW.ECHO-USA.COM or by filling out the warranty registration card supplied with your unit. Registering your product confirms your warranty coverage and provides a direct link if we find it necessary to contact you.

The owner shall demonstrate reasonable care and use, and follow preventative maintenance, storage, fuel and oil usage as prescribed in the operator's manual. Should a product difficulty occur, you must, at your expense, deliver or ship your ECHO unit to an authorized ECHO servicing dealer for warranty repairs (within the applicable warranty period), and arrange for pick-up or return of your unit after the repairs have been made. For your nearest authorized ECHO servicing dealer, call ECHO's Dealer Referral Center, at 1-800-432-ECHO or you can locate an ECHO servicing dealer at WWW.ECHO-USA.COM. Should you require assistance or have questions concerning ECHO's Warranty Statement, you can contact our Consumer Product Support Department at 1-800-673-1558 or contact us through the web at WWW.ECHO-USA.COM.

PRODUCT WARRANTY PERIOD

RESIDENTIAL APPLICATION

- **5 YEAR WARRANTY** - All units for residential, or non-income producing use will be covered by this limited warranty for **five (5) years** from date of purchase.

EXCEPTIONS:

- For two-stroke engine powered products, the electronic ignition module, flexible drive cables, SRM solid drive shafts, and TC tines are warranted for the **life*** of the product on parts only.
- Cutting attachments such as, but not limited to, bars, chains, sprockets, blades, and nylon trimmer heads for residential or non-income producing use will be covered for failures due to defects in material or workmanship for a period of **60 days** from original product purchase date. Any misuse from contact with concrete, rocks, or other structures is not covered by this warranty.
- ECHO's Rapid Loader String Head carries a lifetime warranty on the line locking system, parts only; no labor. Refer to your operator's manual for string head installation and maintenance instructions.
- All SB-Series and PRO ATTACHMENT SERIES Split Shaft attachments carry the same warranty duration as the units they are designed to fit.

COMMERCIAL APPLICATION

- **1 YEAR WARRANTY** - All Chain Saws, QuikVent Saws, and Cut-Off Saws for commercial, institutional, agricultural, industrial, or income producing use will be covered by this limited warranty for one **(1) year** from the date of purchase.
- **2 YEAR WARRANTY** - All other units for commercial, institutional, agricultural, industrial, or income producing use will be covered by this limited warranty for two **(2) years** from the date of purchase.

EXCEPTIONS:

- For two-stroke engine powered products, the electronic ignition module, flexible drive cables, SRM solid drive shafts and TC tines, are warranted for the **life*** of the product on parts only.
- Cutting attachments such as, but not limited to, bars, chains, sprockets, blades, and nylon trimmer heads for commercial, institutional, agricultural, industrial, rental, or income producing will be covered for failures due to defects in material or workmanship for a period of **30 days** from original product purchase date. Any misuse from contact with concrete, rocks, or other structures is not covered by this warranty.
- ECHO's Rapid Loader String Head carries a lifetime warranty on the line locking system, parts only; no labor. Refer to your operator's manual for string head installation and maintenance instructions.
- All SB-Series and PRO ATTACHMENT SERIES Split Shaft attachments carry the same warranty duration as the units they are designed to fit.

RENTAL APPLICATION - 90 DAYS WARRANTY

- Units for rental use will be covered against defects in material and workmanship for a period of 90 days from the date of purchase.

* ECHO's liability under the "Lifetime" coverage is limited to furnishing parts specified under the PRODUCT WARRANTY PERIOD section of this warranty statement for "**Life**" free of charge for a period of ten (10) years after the date of the complete unit's final production.

PURCHASED REPAIR PARTS, SHORT BLOCKS AND ACCESSORIES

- 90-day residential, or non-income producing warranty
- 30-day commercial, institutional, agricultural, industrial, income producing, or rental application warranty

ATTENTION TWO-STROKE ENGINE POWER PRODUCT OWNERS

This ECHO two-stroke engine power product is a quality-engineered unit which has been manufactured to exact tolerances to provide superior performance. To help ensure the performance of the unit, it is required to use two-stroke oil which meets the ISO-L-EGD Standard per ISO/CD 13738 and JASO M345FD Standards. **ECHO Power Blend™ Two-Stroke Oil** is a premium two-stroke oil specifically formulated to meet ISO-L-EGD (ISO/CD 13738) and JASO M345FD Standards. The use of two-stroke oils designed for other applications, such as for outboard motors or lawnmowers can result in severe engine damage, and will void your two-stroke engine limited warranty.

THIS WARRANTY DOES NOT COVER DAMAGE CAUSED BY:

- Lack of lubrication or engine failure, due to the use of two-stroke oils that do not meet the ISO-L-EGD (ISO/CD 13738) and JASO M345FD Standards. Engine problems due to inadequate lubrication caused by failure to use an ISO-L-EGD compliant and JASO M345FD registered oil, will void the two-stroke engine limited warranty. **ECHO Power Blend™ Two-Stroke Oil** meets the ISO-L-EGD and JASO M345FD Standard. Emission related parts are covered for 5 years residential use or 2 years commercial use regardless of two-stroke oil used, per the statement listed in the EPA or California Emission Defect Warranty Explanation.
- Damage caused by use of gasohol, containing methanol (wood alcohol), or gasoline containing less than 89 octane. Only use gasoline which contains 89 octane or higher. Gasohol which contains a **maximum** 10% ethanol (grain alcohol) or 15% MTBE (methyl/tertiary/butyl/ether) is also approved. The prescribed mixing ratio of gasoline to oil is listed on the ECHO oil label and covered in your operator's manual.
- Engine damage caused by use of ether or any starting fluids.
- Damage caused by tampering with engine speed governor or emission components, or running engines above specified and recommended engine speeds as listed in your operator's manual.
- Operation of the unit with improperly maintained/removed cutting shield or removed/damaged air filter.
- Damage caused by dirt, pressure or steam cleaning the unit, salt water, corrosion, rust, varnish, abrasives, and moisture.
- Defects, malfunctions or failures resulting from abuse, misuse, neglect, modifications, alterations, normal wear, improper servicing, or use of unauthorized attachments.
- Incorrect storage procedures, stale fuel, including failure to provide or perform required maintenance services as prescribed in the operator's manual. Preventative maintenance as outlined in the operators manual is the customer's responsibility.
- Failures due to improper set-up, pre-delivery service or repair service by anyone other than authorized ECHO servicing dealer during the warranty period.
- Certain parts and other items are not warranted, including but not limited to: lubricants, starter cords, and engine tune-ups.
- Use of spark plugs other than those meeting performance and durability requirements of the OEM spark plug listed in the Operator's Manuals.
- Overheating or carbon scoring failures due to restricted, clogged exhaust port or combustion chamber, including damage to spark arrester screen.
- Adjustments after the first (30) thirty days and beyond, such as carburetor adjustment and throttle cable adjustment.
- Damage to gears or gear cases caused by contaminated grease or oil, use of incorrect type or viscosity of lubricants, and/or failure to comply with recommended grease or oil change intervals.
- Damage caused by loading SHRED 'N' VAC® beyond recommended capacity.
- Damage caused by pump or sprayer running dry, pumping or spraying caustic or flammable materials, or lack of or broken strainers.
- Additional damage to parts or components due to continued use after operational problem or failure occurs. Should operational problem or failure occur, the product should not be used, but delivered as is to an authorized ECHO servicing dealer.

It is a dealer's and/or customer's responsibility to complete and return the warranty registration card supplied with your ECHO product or by visiting WWW.ECHO-USA.COM. Your receipt of purchase including date, model and serial number must be maintained and presented to an authorized ECHO servicing dealer for warranty service. Proof of purchase rests solely with the customer. Some states do not allow limitations on how long an implied warranty lasts, so the above limitations may not apply to you. Some states do not allow the exclusion or limitation of incidental or consequential damages, so you may also have other specific legal rights which vary from state to state. This limited warranty is given by ECHO Incorporated, 400 Oakwood Rd., Lake Zurich, IL 60047.

DISCLAIMER OF IMPLIED WARRANTIES

This limited warranty is in lieu of all other expressed or implied warranties, including any warranty of FITNESS FOR A PARTICULAR PURPOSE OR USE and any implied warranty of **MERCHANTABILITY** otherwise applicable to this product. ECHO and its affiliated companies shall not be liable for any special incidental or consequential damage, including lost profits. There are no warranties extended other than as provided herein. This limited warranty may be modified only by ECHO.

99922201032

11/18/2011

SERVICING INFORMATION

PARTS/SERIAL NUMBER

Genuine ECHO Parts and ECHO REPOWER™ Parts and Assemblies for your ECHO products are available only from an Authorized ECHO Dealer. When you do need to buy parts **always** have the Model Number, Type and Serial Number of the unit with you. You can find these numbers on the engine housing. For future reference, write them in the space provided below.

Model No. _____ Type _____ SN. _____

SERVICE

Service of this product during the warranty period must be performed by an Authorized ECHO Service Dealer. For the name and address of the Authorized ECHO Service Dealer nearest you, ask your retailer or call: 1-800-432-ECHO (3246). Dealer information is also available on our Web Site. When presenting your unit for Warranty service/repairs, proof of purchase is required.

ECHO CONSUMER PRODUCT SUPPORT

If you require assistance or have questions concerning the application, operation or maintenance of this product you may call the ECHO Consumer Product Support Department at 1-800-673-1558 from 8:30 am to 4:30 pm (Central Standard Time) Monday through Friday. Before calling, please know the model and serial number of your unit.

WARRANTY REGISTRATION

To ensure trouble free warranty coverage it is important that you register your ECHO equipment on-line at www.echo-usa.com or filling out the warranty registration card supplied with your unit. Registering your product confirms your warranty coverage and provides a direct link between you and ECHO if we find it necessary to contact you.

ADDITIONAL OR REPLACEMENT MANUALS

Replacement Operator, Safety Manuals, and Parts Catalogs are available from your ECHO dealer or at www.echo-usa.com or by contacting ECHO Inc., 400 Oakwood Road, Lake Zurich, IL 60047 (800-673-1558). Always check the ECHO Web Site for updated information.

Safety Videos are available from your Echo dealer. A \$5.00 shipping charge will be required for each video.

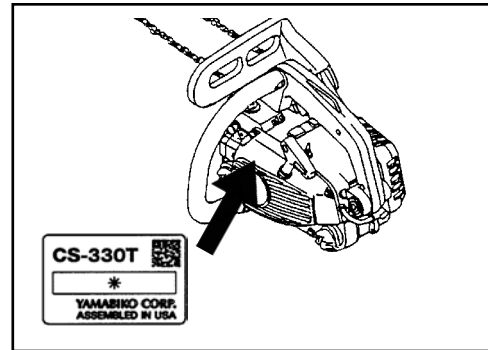

DEALER? Call
1-800-432-ECHO
1-800-432-3246
or
www.echo-usa.com

CONSUMER PRODUCT
SUPPORT
1-800-673-1558
8:30 - 4:30 Mon - Fri C.S.T.

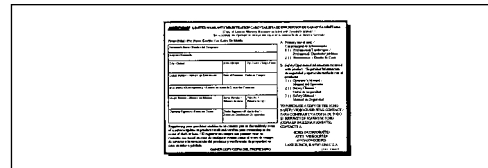

ECHO

ECHO, INCORPORATED

400 OAKWOOD ROAD

LAKE ZURICH, IL 60047-1564

www.echo-usa.com

330T C09613001001/C09613999999